



# Industrial & Commercial Solutions.

ROLL-A-SHUTTERS

ROLL-A-GRILLES

ROLL-A-DOOR MINI-WAREHOUSE

P7 INDUSTRIAL DOORS

SELF-PARKING STRUCTURES

SELF-STORAGE

FACTORIES

SHOPFRONTS





## STANDARD COLLECTION

LARGE OPENINGS

# Roll-A-Shutter™

The B&D Roll-A-Shutter Standard Collection is suitable for a wide range of industrial and commercial requirements and features a selection of shutters for virtually any application – from the largest building complexes to small single factories and warehouses.

## THE RANGE

### 6/100 (0.6mm x 100mm)

For all-round light industrial applications – manual, chain-gearred or powered options

### 8/100 (0.8mm x 100mm)

For most general purpose applications such as medium-sized factory doorways – manual, chain-gearred or powered options

### 10/100 (1.0mm x 100mm)

For heavy-duty wind loading and large openings – chain-gearred or heavy-duty powered options

### 12/100 (1.2mm x 100mm)

Robust access door, for building perimeter security or storage applications – manual, chain-gearred or powered options

## SPACE REQUIREMENTS

HEIGHT	HEADROOM	BACKROOM	DRIVE END SIDE ROOM		PLAIN END SIDE ROOM
			CHAIN OP	ELECTRIC OP	
2195 to 3195	700	500	329	401	285
3200 to 3795	700	500	329	401	285
3800 to 4895	720	520	329	401	285
4900 to 6000	760	560	329	401	285

## STANDARD FEATURES

- Weatherseals
- Aluminium bottom rail
- Standard guide-mounted lockable chain clip for all electric and chain-operated shutters
- Full range of powdercoat or galvanised slats
- Heavy-duty steel drum and bracket assemblies
- Steel curtain
- 70mm deep galvanised steel standard channel guide
- 90mm deep galvanised steel highwind guide. (Registered Design No.357673)
- Recommended Opener: ATA 3000, 3100 or GFA Springless

# 8/50 Industrial Roll-A-Shutter.

The 8/50 Roll-A-Shutter curtain is made from 0.8mm thick galvanised steel with zinc coating of no less than 275g/m<sup>2</sup>, roll-formed into a deep profile slat with a nominal effective width of 50mm. The curtain is fitted with moulded nylon clips to the ends of alternate slats. Optional malleable iron clips can be specified for areas where high temperatures are encountered.



## STANDARD FEATURES

- Chain-drive: Fitted with a spur gear attached to one end of the drum and meshing with a number of gears to give a desired gear ratio depending on shutter size. Motor-drive: fitted with a sprocket to one end of the drum and driven by transmission chain
- Shutter support brackets are fabricated from 50mm x 50mm x 6mm mild angle steel
- Helical torsion type springs made from spring steel wire conforming to AS1472
- Various locking options available
- Curtain, guides and box bottom rails are zinc coated galvanised steel
- Bottom rails are mill-finished aluminium

# 8/50

### 0.8mm x 50mm STEEL SLATS

EXTRUDED GUIDES: 50mm x 2.5mm

### BEST FOR

Commercial, small and light industrial applications like kiosks, shops, trucks and vans

The 8/50 is a manual operation without a chain wheel. Two types of guides are used, fixed securely to the walls at intervals of not more than 750mm x 9.5mm

1. 50mm channel made from a 2.5mm thick material
2. 75mm channel made from a 3.2mm thick material

### OPENINGS

From 900mm by 900mm to 5000mm x 5000mm

### ROLLER DRUM

For openings up to and including 2100mm x 2100mm, an 89mm diameter steel tube with a wall thickness of 1.6mm is used. For openings above 2100mm x 2100mm, a 168mm diameter steel tube with a wall thickness of 3.2mm is used

### RECOMMENDED OPENER

Axess Pro 3300 or 3100 Shutter Opener

## DIMENSIONS

	GUIDES	A1	A2	B rec	B min	C
MANUAL - No chain wheel	50mm	180	180	500	450	300
Up to 5.9m <sup>2</sup> 2750 h or 2750 w	75mm	200	200	500	450	300
Chain gear op. to 9.3m <sup>2</sup>	50mm	220	180	530	480	330
Up to 5000 h or 5000 w	75mm	240	200	530	480	330
Chain gear op. to 25m <sup>2</sup>	50mm	260	180	560	510	360
Up to 5000 h or 5000 w	75mm	280	200	560	510	360
Electric operation option	<b>GUIDES</b>	<b>INSIDE MOUNT</b>		<b>OUTSIDE MOUNT</b>		
	50mm	210		440		
	75mm	230		460		
50mm guides are supplied as a standard on opening widths up to 3050mm						

## CLEARANCES

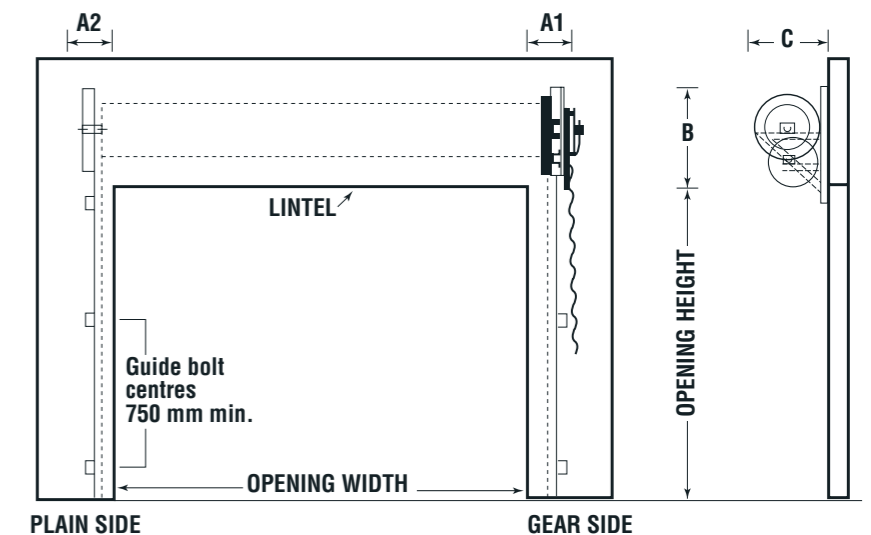



# ROLL-A-SHUTTERS

# Series 40/65/90.

Our aluminium range of Roll-A-Shutters uses a combination of curtains and slat styles to suit different applications from sporting complexes, shopfronts and bars to shopping centre shopfronts, arcades and secure parking structures.



## STANDARD FEATURES

- Alternative aluminium sections are fitted with moulded end clips to reduce friction
- Spring assisted drum assembly – central shaft carries helical springs to ensure smooth effortless operation
- Can be motorised or manually operated
- Versatile tracking system can be mounted between or behind wall fix
- Can be fitted with a centrally mounted locking system (not recommended for motorised doors)
- Provide 95mm x 25mm vent slots at 70mm spacing as required in roller shutter
- Slotting may include polycarbonate backing panel to reduce foreign particle entry
- Supplied with a sturdy T-Rail bottom rail providing additional strength

# 40

40mm x 1.6mm  
ALUMINIUM EXTRUSION

EXTRUDED GUIDES: 50mm x 30mm

### BEST FOR

Sporting complexes, clubs, bars, fire reel enclosures and counter tops.

A slimline flat slat curtain which can be slotted on request to provide ventilation.

### OPENINGS

From 1000mm to 4000mm (High) and up to 6400mm (Wide) Please add to the end of line to a maximum of 16m<sup>2</sup>

### ROLLER DRUM

150mm or 229mm spiral drum rotating on 34mm heavy duty shaft, fitted with high speed industrial bearing and helical springs

### RECOMMENDED OPENER

Central Motor or ATA GDO-12 and Smart Phone Control Kit

## CLEARANCES

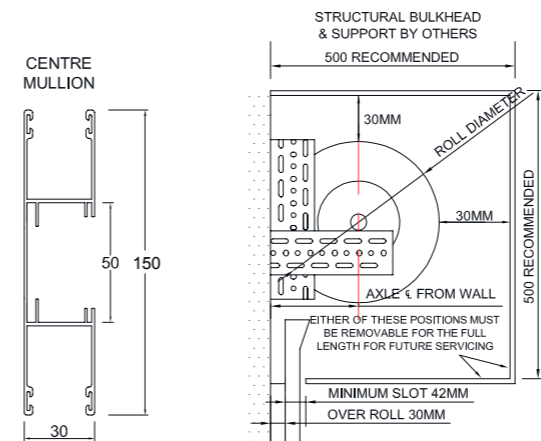

## DIMENSIONS

DOOR HEIGHT	DRUM 150MM		DRUM 229MM	
	ROLL DIAMETER	CENTRE AXLE FROM WALL	ROLL DIAMETER	CENTRE AXLE FROM WALL
900	260	140	305	162
1200	260	140	305	162
1500	260	140	320	170
1800	270	145	330	175
2100	270	145	350	185
2400	280	150	350	185
2700	300	160	360	190
3000	300	160	370	195
3300	340	180	380	200
3600	360	190	395	207

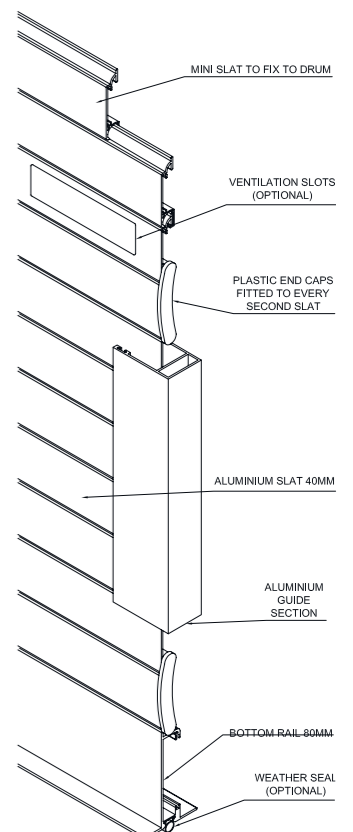
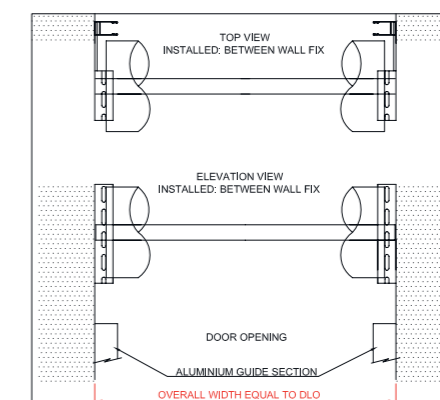
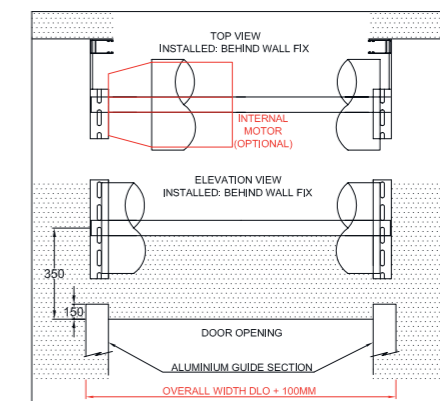

# 65

## 65mm x 1.6mm ALUMINIUM EXTRUSION

EXTRUDED GUIDES: 50mm x 30mm

### BEST FOR

Retail shop fronts, arcades, clubs and bars

An interlocking flat curtain designed to provide an attractive appearance. The door curtain can be slotted to create a different design or increase ventilation

### OPENINGS

From 1000mm to 4000mm (High) and up to 6000mm (Wide) to a maximum of 16m<sup>2</sup>

### ROLLER DRUM

148mm or 229mm spiral drum rotating on 34mm heavy duty shaft, fitted with high speed industrial bearing and helical springs

### RECOMMENDED OPENER

Central Motor or ATA GDO-12 and Smart Phone Control Kit

## DIMENSIONS

DOOR HEIGHT	DRUM 150MM		DRUM 229MM	
	ROLL DIAMETER	CENTRE AXLE FROM WALL	ROLL DIAMETER	CENTRE AXLE FROM WALL
900	260	140	305	162
1200	260	140	305	162
1500	260	140	320	170
1800	270	145	330	175
2100	270	145	350	185
2400	280	150	350	185
2700	300	160	360	190
3000	300	160	370	195
3300	340	180	380	200
3600	360	190	395	207

## CLEARANCES

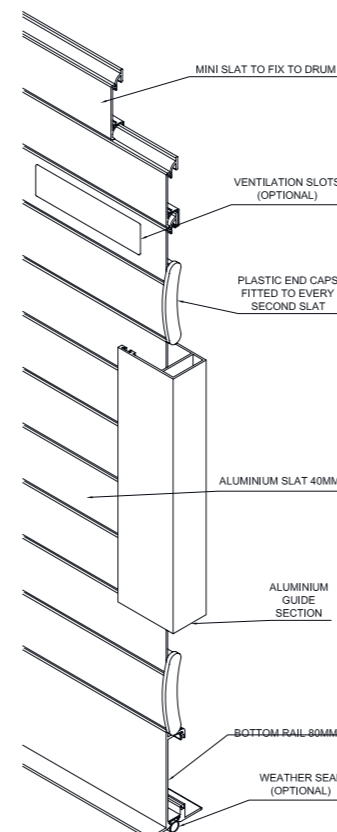
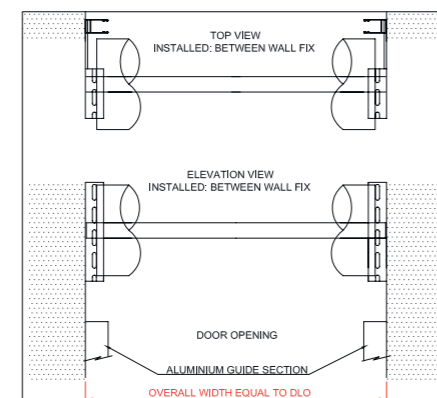
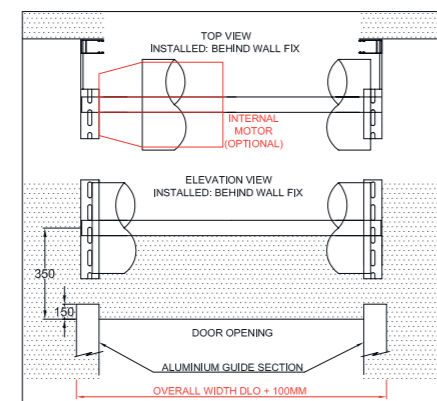
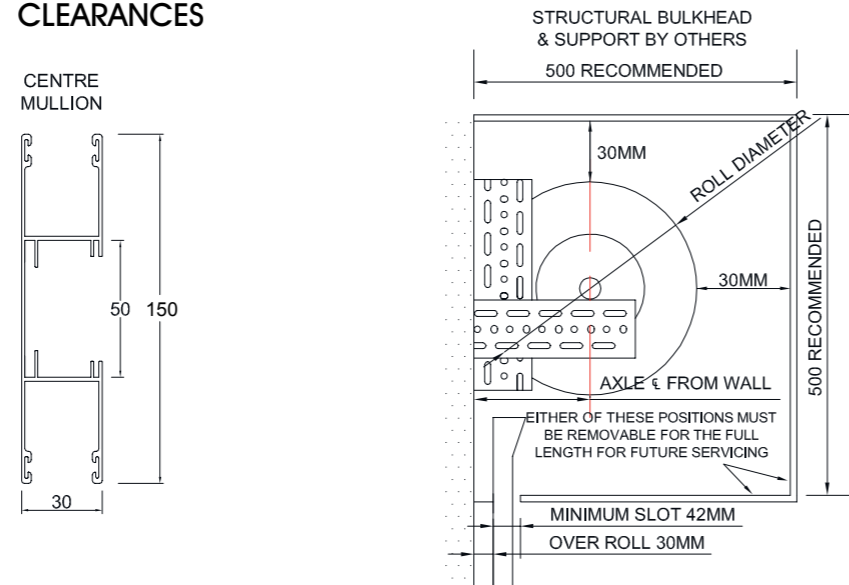

# 90

## 90mm x 1.4mm ALUMINIUM EXTRUSION

EXTRUDED GUIDES: 100mm x 38mm

### BEST FOR

Shop fronts, secure parking structures, arcades, clubs and bars.

Heavy duty aluminium extrusion curtain, ensures maximum security. Built using solid aluminium interlocking sections and can be slotted or perforated

### OPENINGS

From 1000mm to 4500mm (High) and up to 8000mm (Wide)

### ROLLER DRUM

165mm or 229mm spiral drum rotating on 34mm heavy duty shaft, fitted with high speed industrial bearing and helical springs

### RECOMMENDED OPENER

Axess Pro 3300 and 3100 or GFA Springless

## DIMENSIONS

DOOR HEIGHT	DRUM 150MM		DRUM 229MM	
	ROLL DIAMETER	CENTRE AXLE FROM WALL	ROLL DIAMETER	CENTRE AXLE FROM WALL
1000	260	140	325	173
1500	275	148	346	183
2000	325	173	356	188
2500	360	190	380	200
3000	360	190	392	206
3500	390	205	400	210
4000	410	215	420	220
4500	420	215	420	220

## CLEARANCES

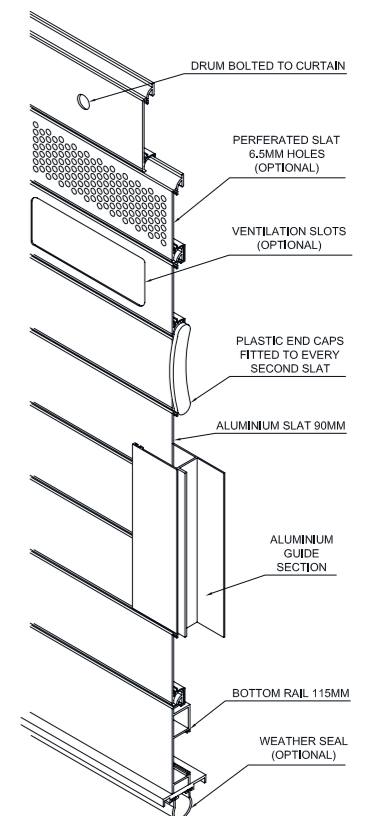
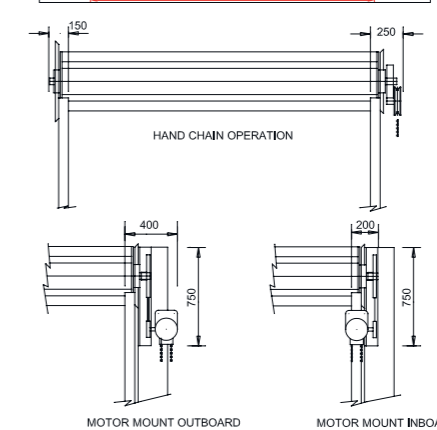
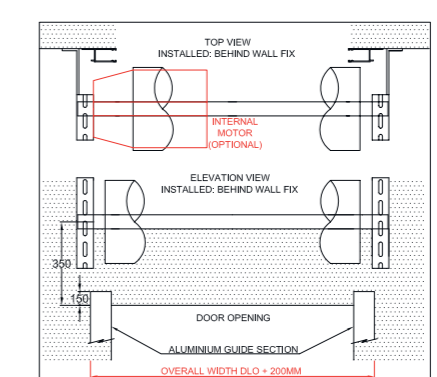
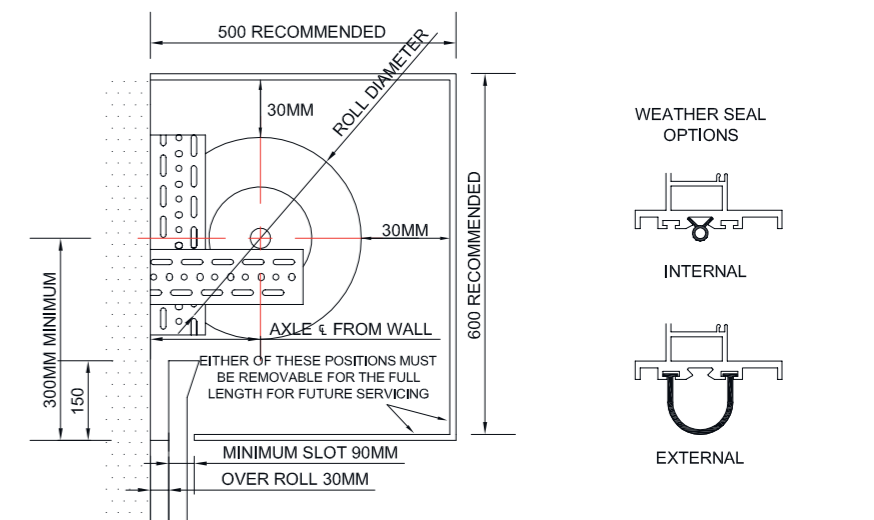



## ROLL-A-SHUTTERS

# Clear-A-View Polycarbonate Shutter.

The B&D Roll-A-Shutter Clear-A-View Industrial Type Poly Carbonate Shutters are specifically designed with retailers in mind. They allow for continual showcasing and product advertisement when the door is closed. They can be supplied in a vast range of sizes colour finishes.



## STANDARD FEATURES

- Supplied with a sturdy aluminium T-Rail bottom rail providing additional strength to the door
- Curtain is 100mm polycarbonate interlocking with 30mm rigid aluminium sections with moulded end caps to reduce friction.
- The 50mm x 35mm versatile aluminium door tracks can be mounted between wall fix or behind wall fix
- May be fitted with a centrally mounted locking mechanism within the mid-rail at approximately 900mm above floor level or within the bottom rail
- Slotting – can be provided at 95mm x 25mm vent slots at 70mm spacing where required in the roller shutter

## Clear-A-View

100mm POLY CARBONATE INTERLOCKING WITH 30mm RIGID ALUMINIUM SECTIONS. RUNNING IN 50mm x 30mm ALUMINIUM DOOR TRACKS.

### BEST FOR

Shopfronts, arcades, sporting complexes, clubs, bars and counter tops

### OPENINGS

From 1000mm by 4000mm (High) and up to 6400mm (Wide)

### ROLLER DRUM

229mm spiral drum rotating on 34mm heavy duty shaft fitted with high speed industrial bearing and helical springs

### RECOMMENDED OPENER

Central Motor, ATA GDO-12 and Smart Phone Control Kit

## DIMENSIONS

DOOR HEIGHT	ROLL DIAMETER	CENTRE AXLE FROM WALL
900	290	155
1200	290	155
1500	290	155
1800	300	160
2100	300	160
2400	310	165
2700	310	165
3000	320	170
3300	320	170
3600	340	180
4000	340	180

## CLEARANCES

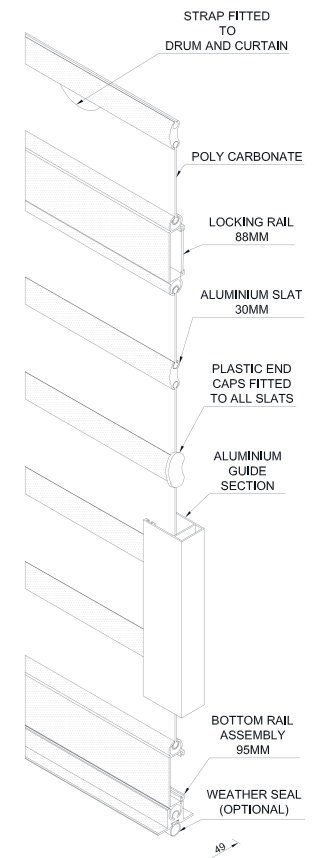
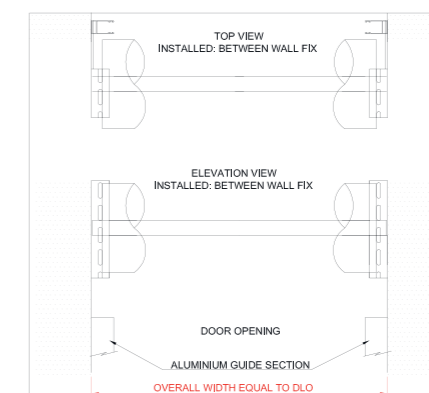
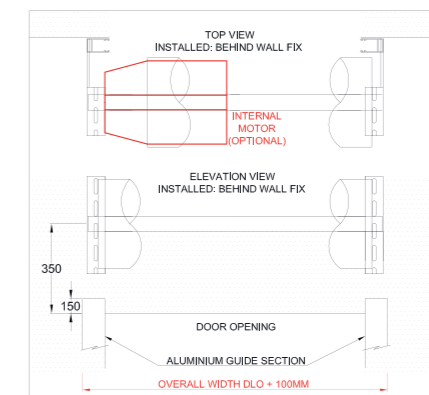
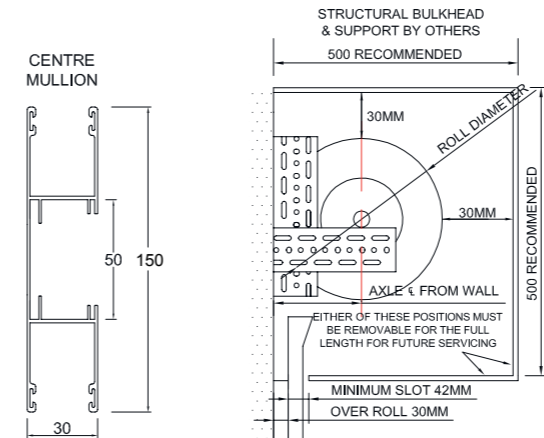



## ROLL-A-GRILLES

# Roll-A-Grilles

The Industrial Grille-type Aluminium Shutters have a sleek, easy to operate aluminium curtain, specifically designed from aluminium extrusion for a high level of security. They are a cost-effective product designed to maintain the feeling of openness between internal and external spaces, where ventilation or visual product branding is needed.



## STANDARD FEATURES

- Supplied standard in a clear anodised finish (Matt Natural), but can be powder coated as an optional extra
- Sturdy T-Rail aluminium bottom rail providing additional strength
- 50mm x 30mm aluminium door tracks can be mounted between wall fix or behind wall fix
- May be fitted with central mounted locking mechanism within the bottom rail. Locking mechanism is generally concealed

# 12

## 12mm ALUMINIUM EXTRUSION TUBING

### EXTRUDED GUIDES: 50mm x 30mm

Constructed from 12mm aluminium extrusion tubing connected with 100mm links creating a symmetrical, brick-like pattern

### BEST FOR

Arcades, sporting complexes, clubs, bars and counter tops,

### OPENINGS

From up to 4000mm (High) and up to 5000mm (Wide)

### ROLLER DRUM

148mm or 229mm spiral drum rotating on 34mm heavy duty shaft fitted with high speed industrial bearing and helical springs

Curtain has 12mm aluminium extrusion tubing at 47mm centres interconnected with 100mm x 100mm links spaced at 440mm centres

### RECOMMENDED OPENER

Central Motor, ATA GDO-12 and Smart Phone Control Kit

## CLEARANCES

### CENTRE MULLION

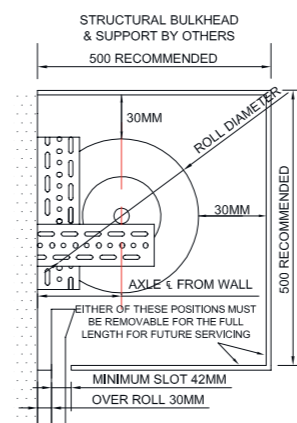
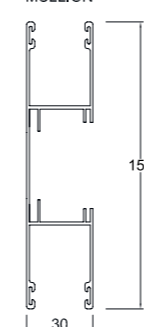

## DIMENSIONS

DOOR HEIGHT	DRUM 229MM	
	ROLL DIAMETER	CENTRE AXLE FROM WALL
900	310	165
1200	315	167
1500	325	172
1800	330	175
2100	350	185
2400	365	192
2700	375	197
3000	380	200
3300	390	205
3600	420	220
4000	440	230

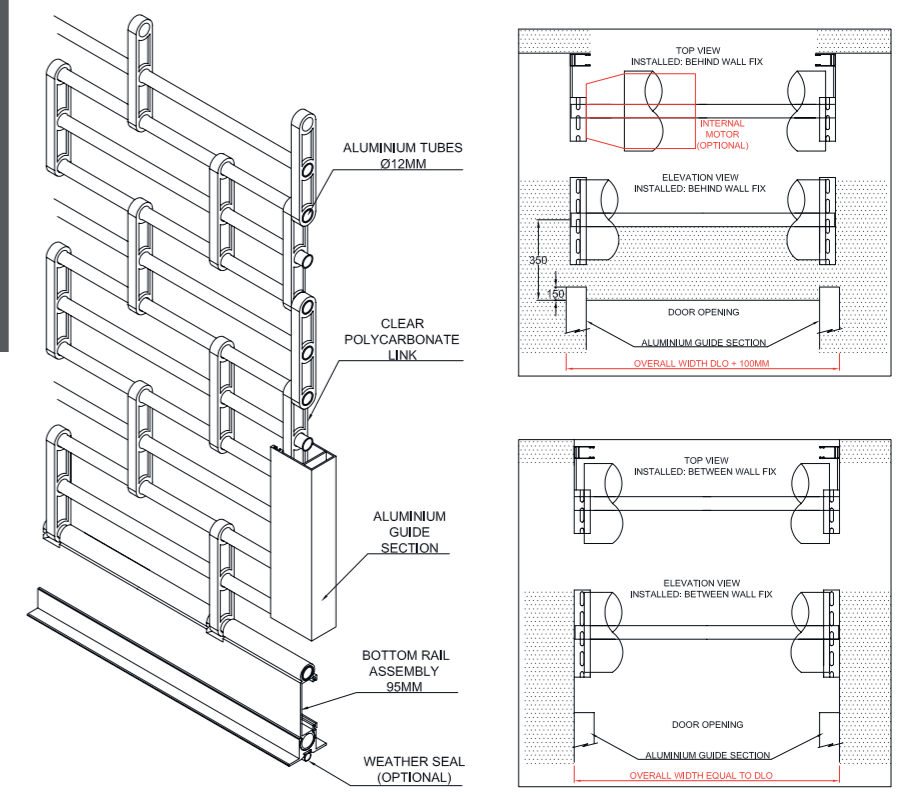



## ROLL-A-GRILLES

# Roll-A-Grilles

The Industrial Grille-type Aluminium Shutters have a sleek, easy-to-operate aluminium curtain, specifically designed from aluminium extrusion for a high level of security. They are a cost-effective product designed to maintain the feeling of openness between internal and external spaces, where ventilation or visual product branding is needed.



## STANDARD FEATURES

- Supplied standard in a clear anodised finish (Matt Natural), but can be powder coated as an optional extra
- Sturdy T-Rail aluminium bottom rail providing additional strength
- 100mm x 35mm aluminium door tracks can be mounted between wall fix or behind wall fix
- May be fitted with central mounted locking mechanism within the bottom rail. Locking mechanism is generally concealed

# 19

## 19mm ALUMINIUM EXTRUSION TUBING

### DOOR TRACKS: 105mm x 40mm

Constructed from 19mm aluminium extrusion tubing with 35mm links creating a symmetrical brick-like pattern

### BEST FOR

Arcades, sporting complexes, clubs, bars, counter tops and car park common entry

### OPENINGS

range from 100mm to 1000mm (High) and up to 8000mm (Wide)

### ROLLER DRUM

165mm or 229mm spiral drum rotating on 34mm heavy duty shaft fitted with high speed industrial bearing and helical springs

Curtain has 19mm aluminium extrusion tubing at 75mm centres interconnected with 35mm x 3mm links spaced at 50mm centres

### RECOMMENDED OPENER

Central Motor, Axxess Pro 3300 or 3100, GFA Springless

## CLEARANCES

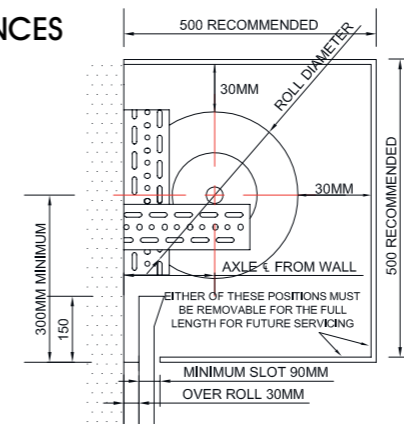

## DIMENSIONS

DOOR HEIGHT	DRUM 165MM		DRUM 229MM	
	ROLL DIAMETER	CENTRE AXLE FROM WALL	ROLL DIAMETER	CENTRE AXLE FROM WALL
1000	326	173	326	173
1500	326	173	378	199
2000	330	175	394	207
2500	364	192	398	209
3000	378	200	434	227
3500	415	218	448	234
4000	435	228	453	237
4500	460	240	470	245

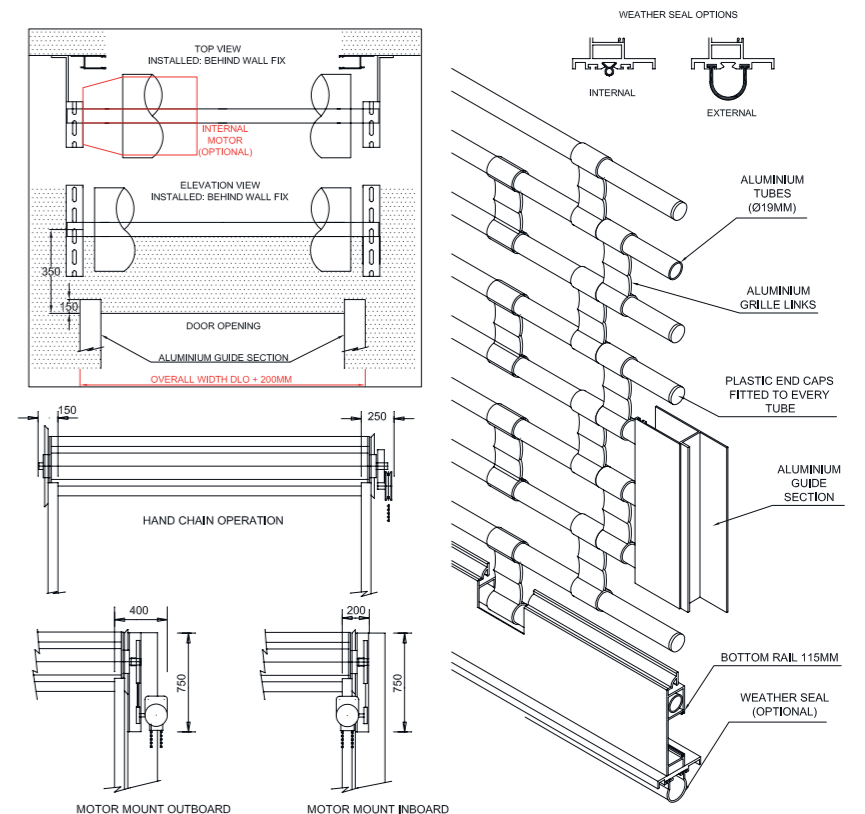



## ROLL-A-DOORS

# Mini Warehouse.

Roll-A-Door S1 Mini Warehouse door delivers high standards of durability, security, operational ease, and most importantly, product longevity.



## STANDARD FEATURES

- Smooth, quiet operation
- High wind rated roller door
- Precision springing
- Consistent balance
- Bottom weatherseal
- Wide range of colours
- 7 Year warranty on door

## RTM

### .4MM CONTINUOUS PRESSED SQUARE-LINE STEEL CURTAIN.

### GALVANISED GUIDES: 25MM

Constructed from .4mm steel curtain with Nylofelt® to minimise friction ensuring a continuous smooth, quiet operation.

### BEST FOR

Storage centres, kiosks, mini warehouses and shopfronts

### OPENINGS

Range from 1250mm to 3000mm (High) and up to 3150mm (Wide)

### ROLLER DRUM

Castellated steel drum and mini groove top sheet reduces paint scuffing and promotes ease of operation.

Spring life designed for 20,000 cycles.

### RECOMMENDED OPENER

ATA GDO-10, ATA GDO-12 and Smart Phone Control Kit

### LOCKING OPTIONS



External Stainless Steel Slide Lock



External Traditional Recessed Slide Lock



External Stainless Steel Overlocker

## DIMENSIONS

SIZE	MINIMUM DOOR SIZE	MAXIMUM DOOR SIZE
Height	1250mm	3000mm
Width	940mm	3150mm

HEIGHTS	INSTALLATION CLEARANCES								
	HEADROOM (mm)				SIDEROOM (mm)				
	RECOMMENDED		RESTRICTED		E1		E2		
	A	B	C	D	A	C	LH	RH	
Series 1 Up to 2100	350	80	120	460	315	85	100	140	155
2101 – 3000	370	80	120	480	335	100			

## CLEARANCES

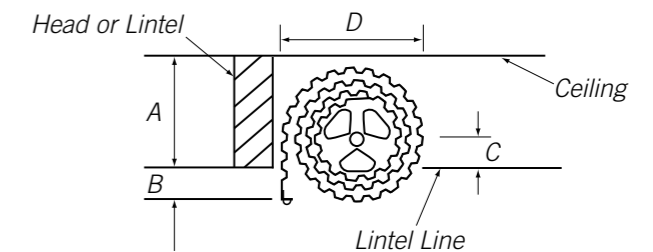

Door Roll Obstruction

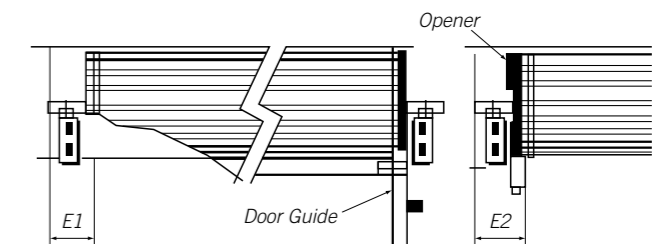

(Drawings not to scale)

## SPECIAL COLOURS



Lazurite Blue



Signal Red



Mandarine Orange



Aztec Yellow



## SECTIONAL DOORS

# P7 Industrial

The B&D P7™ Industrial door is an innovative, sectional overhead panel door that can be purposely designed to suit its application. The lightweight aluminium frame of the P7 Industrial holds different styles of panel inserts from a range of long lasting, durable materials including acrylic and aluminium. P7 Industrial can be installed with an aluminium finish or with a choice of over 100 powder coat colours – enough to complement any commercial building's décor.



## STANDARD FEATURES

- Large range of sizes from 1370mm (h) x 1800mm (w) to 4500mm (h) x 7620mm (w)
- Range of insert options available to suit your application
- Custom panel sizes and evenly spaced insert openings ensure your door looks symmetrical and aesthetically pleasing
- Soft pliable weatherseal helps stop leaves and rain entering under the door
- Frame manufactured from industrial strength anodised aluminium and available in an extensive powder coating colour selection, to compliment your colour scheme

## P7

### 12 INSERT STYLES TO CHOOSE FROM.

### RUNNING IN 1.5MM GALVABOND® Z250 GUIDES.

Constructed from 1.5mm box shaped aluminium extruded frame, screwed together with a range of insert options to choose from.

### BEST FOR

carparks, private parking, kiosks, shopping centres, shopfronts

### OPENINGS

Range from 1370mm to 4500mm (High) and up to 7620mm (Wide)

### OPERATION

We recommend you automate your P7 Industrial Door. Ask us for the best option for added operational convenience

High cycles spring option available

### RECOMMENDED OPENER

Axess Pro 1505

## DIMENSIONS

SIZE	MINIMUM DOOR SIZE	MAXIMUM DOOR SIZE
Height	1370mm	4500mm
Width	1800mm	7620mm

## INSTALLATION REQUIREMENTS

### INSTALLATION CLEARANCES – STANDARD HEADROOM

From - To (inc.) Height	HEADROOM (mm)						SIDEROOM (mm)
	RECOMMENDED			WITH OPENER*			RECOMMENDED EACH SIDE
	Up to 4710W	4710 - 5285W	Over 5285W	Up to 4710W	4710 - 5285W	Over 5285W	
1370 - 2440	340	340	390	440	440	490	120
2445 - 3050	340	340	390	440	440	490	120
3055 - 3660	340	390	390	440	490	490	120
3665 - 4500	390	390	390	490	490	490	120

### INSTALLATION CLEARANCES – LOW HEADROOM

From - To (inc.) Height	HEADROOM (mm)						SIDEROOM (mm)	
	RECOMMENDED			WITH OPENER*			RECOMMENDED EACH SIDE	
	Up to 4710W	4710 - 5285W	Over 5285W	Up to 4710W	4710 - 5285W	Over 5285W	Up to 15m2	Over 15m2
1370 - 2440	190	190	190	290	290	290	155	195
2445 - 3050	190	190	200	290	290	300	155	195
3055 - 3660	190	200	200	290	300	300	155	195
3665 - 4500	200	200	200	300	300	300	155	195

\*Clearance calculated using Industrial Opener specifications.

## INSERT OPTIONS

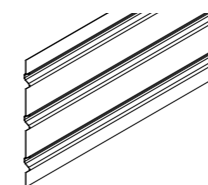

Alumpanel

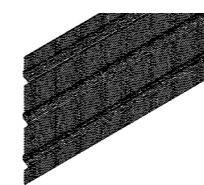

Alumpanel with Air

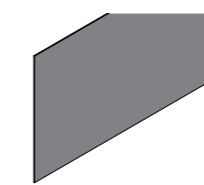

Steel flat panel

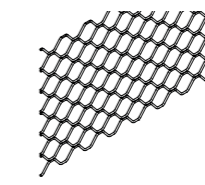

Airpanel

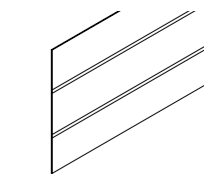

Steel ribbed panel

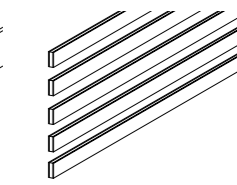

Aluminium slatted

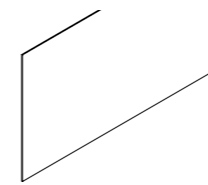

Clear acrylic

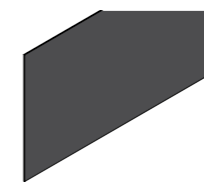

Smoke acrylic

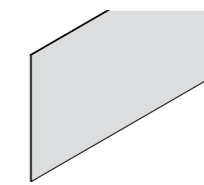

Opaque acrylic

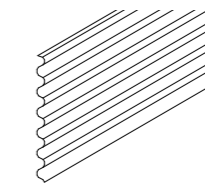

Mini corrugated steel

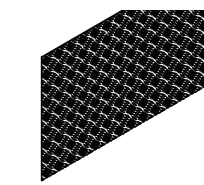

Aluminium checker plate



Your B&D® Representative is:



**GARAGE DOORS  
AND MORE**

NEWCASTLE 02 4954 3886 TAMWORTH 02 6760 9372

For more details on these products or our other ranges,  
call **13 62 63** or visit **[www.bnd.com.au](http://www.bnd.com.au)**

B&D Doors & Openers is a division of B&D Australia Pty Ltd, ABD 25 010 473 971.  
© 2019 B&D Australia.